



OWNER'S / OPERATOR'S
MANUAL

G-MAX 48 VOLT

GOLF CAR G22E

INTRODUCTION

Congratulations on your purchase of a Yamaha golf car. This manual contains information you will need for proper operation, maintenance, and care of your golf car. A thorough understanding of these simple instructions will help you to obtain maximum enjoyment from your new Yamaha.

If you have any questions about the operation or maintenance of your golf car, please consult a Yamaha dealer.

YAMAHA MOTOR MANUFACTURING CORP OF AMERICA

**G22E
OWNER'S/OPERATOR'S
MANUAL**

**© 2004 by Yamaha Motor
Manufacturing Corporation
of America
1st edition**

**All rights reserved. Any reprinting
or unauthorized use without the
written permission of
Yamaha Motor Manufacturing
Corporation of America
is expressly prohibited.**

**Printed in U.S.A.
P/N LIT-19626-00-79**

IMPORTANT MANUAL INFORMATION

Particularly important information is distinguished in this manual by the following notations:



The Safety Alert Symbol means **ATTENTION! BE ALERT! YOUR SAFETY IS INVOLVED!**

⚠ WARNING

Failure to follow WARNING instructions could result in severe injury or death to the golf car occupants, a bystander, or a person inspecting or repairing the golf car.

CAUTION

This message describes special precautions that must be taken to avoid damage to the golf car.

NOTE:

This message provides additional key information.

NOTE:

- Yamaha continually seeks advancements in product design and quality; therefore, while this manual contains the most current product information available at the time of printing, there may be minor discrepancies between your golf car and this manual. If you have any questions concerning this manual, please consult your Yamaha dealer.
- This manual should be considered a permanent part of your golf car and should remain with the car when resold.

⚠ WARNING

Read and understand this manual completely before operating your golf car.

CONTENTS

WARRANTY

1

IMPORTANT LABELS

2

OPERATOR SAFETY

3

MAINTENANCE SAFETY PROGRAM

4

CONTROLS

5

PRE-OPERATION CHECKS

6

OPERATION

7

MAINTENANCE

8

STORAGE

9

SPECIFICATIONS

10

WIRING

11

WARRANTY

YAMAHA MOTOR MANUFACTURING CORPORATION OF AMERICA LIMITED 3-YEAR GOLF CAR WARRANTY

Yamaha Motor Manufacturing of America hereby warrants that any new Yamaha Golf Car (gas and electric models) purchased from an authorized Yamaha dealer in the United States will be free from defects in material and workmanship for THREE years from date of purchase, subject to the stated limitations.

DURING THE PERIOD OF WARRANTY any authorized Yamaha Golf Car Dealer will, free of charge, repair or replace, at Yamaha's option, any part adjudged defective by Yamaha due to faulty workmanship or material from the factory. Parts used in warranty repairs will be warranted for the balance of the machine's warranty period. All parts replaced under warranty become property of Yamaha Motor Manufacturing Corporation of America.

GENERAL EXCLUSIONS from this warranty shall include any failures caused by:

- a. Abnormal strain, neglect, or abuse, including lack of proper maintenance, and use contrary to the Owner's/Operator's Manual instructions.
- b. Accident or collision damage.
- c. Installation of parts or accessories that are not original equipment.
- d. Fading, rust, or deterioration due to exposure or ordinary wear and tear.
- e. Modifications or alteration that affects the car's condition, operation, performance, or durability, or which makes the car serve a purpose other than use as a two-person, golf course vehicle.
- f. Damage due to improper transportation.
- g. Acts of God, ie: lightning, hail damage, flooding, fire, etc.

SPECIFIC EXCLUSIONS: The first year of warranty shall cover the entire car except for batteries, battery chargers, tires and rims, which are warranted by their respective manufacturers. Parts excluded from the second year of warranty include the body parts, seats, mats, bumper assembly, bag carrier, scorecard holder, and the trim. Parts excluded from the third year of warranty include the second year exclusions, the electrical system (except electronic speed controller and electric motor) and control cables. Other specific exclusions from this warranty shall include any parts replaced due to normal wear or routine maintenance, including oil, air filter elements, brake shoes, spark plugs, starter and clutch drive belts. Any charges incurred in transporting a golf car to and from an authorized Yamaha Golf Car Dealer for service or in performing field service are also excluded from this warranty.

IMPORTANT LABELS

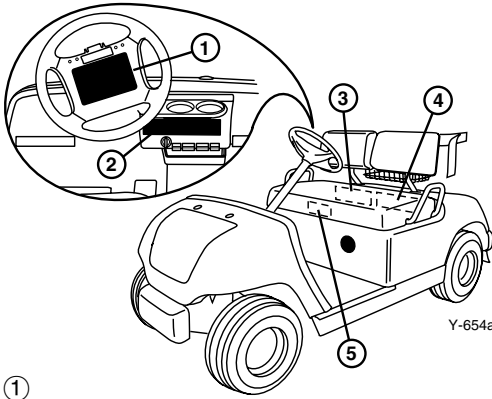

SAFETY AND INSTRUCTION LABELS

WARNING

Please read the following labels carefully before operating your golf car, and promptly replace any labels which become damaged or removed.

2

OPERATING INSTRUCTIONS

- Read the warning label on the beverage holder panel before operating.
- Be sure occupants are seated.
- Select "FORWARD" or "REVERSE" then turn main switch to "ON".
- Press the accelerator pedal to start moving. The motor will start and the parking brake will release automatically.
- To stop, release the accelerator pedal and press the brake pedal.
- Never travel at speeds too fast for the terrain, visibility conditions, or your experience.
- Drive with extra caution in congested areas, when operating in reverse, and when driving on wet, rough, or loose surfaces.
- Come to a complete stop before reversing direction.
- Press the parking brake pedal until it locks, and turn the main switch to "OFF" before leaving the vehicle.
- Read the Owner's/Operator's Manual for more information.

ATTENTION

- This vehicle was not manufactured for use on public streets and does not comply with federal motor vehicle safety standards applicable to passenger cars.

YAMAHA

JUO-K7762-00

Y-500

BATTERY INSTALLATION AND WIRE LEAD CONNECTION

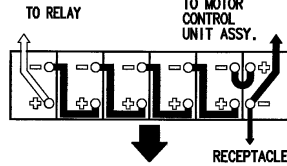

YAMAHA

JUO-K7765-00

Y-655

WARNING

DEATH OR SEVERE PERSONAL INJURY CAN RESULT FROM FAILURE TO FOLLOW THESE INSTRUCTIONS.

- Read Operating Instructions on steering wheel before operation.
- Operate only when authorized and only in designated areas.

OFF

REV FWD

- Operate from driver's side only.
- Do not allow more than two occupants in vehicle.
- Do not start vehicle until all occupants are seated.
- Remain seated and hold on when in motion.
- Keep entire body inside vehicle.
- Drive slowly in turns.
- Drive slowly straight up and down slopes.
- Set parking brake before leaving vehicle.
- Turn main switch to "OFF" and remove key when not in use.
- Do not operate while under the influence of alcohol or drugs.

YAMAHA

JR1-K7768-00

Y-656

WARNING/AVERTISSEMENT



EXPLOSIVE GASES

are released when batteries are charged or discharged. Keep sparks, flames and cigarettes away. Shield eyes when working near batteries.

LES GAZ EXPLOSIFS

se dégagent lors de la charge ou de décharge des batteries. Garder bien ventilé. Garder étincelles, flammes et cigarettes à l'écart des batteries. Se protéger les yeux lorsque l'on travaille près des batteries.



SULFURIC ACID

in batteries will burn skin, eyes, and clothing. Do not tip battery. Keep vent caps tight and water. In event of injury, flush with water and call physician immediately.

L'ACIDE SULFURIQUE

dans les batteries brûle la peau, les yeux et les vêtements. Ne pas renverser les batteries. Garder les bouchons serrés et horizontaux. En cas de contact avec l'acide, nettoyer à grande eau et appeler le médecin immédiatement.



ELECTRICAL SHORTS

can result in burns. Do not make connections between positive and negative battery terminals.

LES COURTS-CIRCUITS ELECTRIQUES

peuvent causer des brûlures. Ne pas relier la borne positive et la borne négative d'une même batterie.

4

Y-843

CAUTION/AVERTISSEMENT

Move switch to the "TOW" position before towing or storage. Failure to do so may lead to:

- Drive system damage or electrical fire when towing.
- Complete battery discharge and battery damage when storing long term.
- NOTE: After moving switch from "RUN" to "TOW" wait 15 seconds minimum before switching again.

Mettre l'interrupteur à position "TOW" avant de remorquer ou avant l'entreposage.

Non-observation pourrait endommager le système d'actionnement ou causer un incendie électrique pendant le remorqué.

causer une décharge totale de la batterie et endommager la batterie pendant l'entreposage à long terme.

NOTE: Après avoir changé l'interrupteur de position "RUN" à position "TOW", attendre un minimum de 15 secondes avant de le remettre.

YAMAHA

JR1-K7769-00

Y-844

IMPORTANT LABELS

2

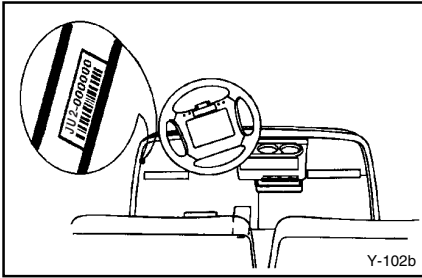

GOLF CAR SERIAL NUMBER

The golf car serial number is stamped in the location shown.

NOTE: _____

The first three digits of the serial number are for model identification; the remaining digits are the unit production number. Keep a record of these numbers for reference when ordering parts from a Yamaha dealer.



OPERATOR SAFETY

Yamaha golf cars are designed to be simple to operate. However, be sure to observe the following:

BEFORE OPERATING THE GOLF CAR



- Read this Owner's/Operator's manual and all safety and instruction labels on the golf car before operating.
- Perform the pre-operation checks found in Section 6 of this manual.
- Only authorized people should drive the golf car, from the driver's side only, and only in designated areas.
- Do not allow more than two people to ride in the golf car. This golf car is restricted to two occupants.
- Do not operate the golf car while under the influence of alcohol or drugs; their affect on vision and judgment make operating a golf car dangerous.
- Do not operate the golf car on public streets, roads or highways. Such use is prohibited by law, and dangerous. Operation on public roads can result in collision with other vehicles.

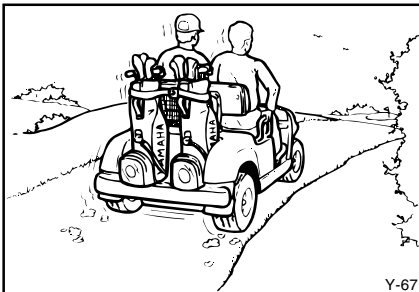

WHILE OPERATING THE GOLF CAR

- Keep your entire body inside the golf car, remain seated, and hold on when the car is in motion.
- Do not start the golf car until all occupants are seated.



OPERATOR SAFETY

3

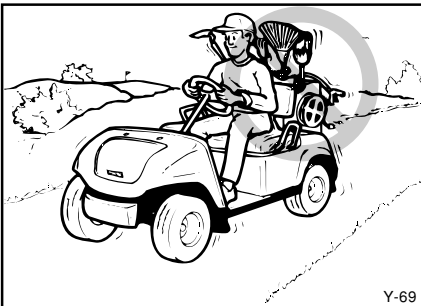
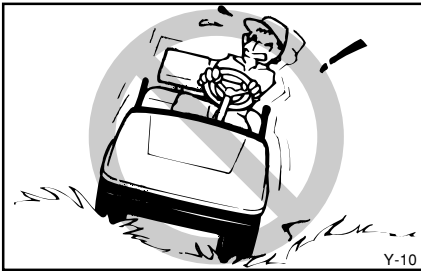

- Keep your hands on the steering wheel and your eyes on the path ahead.
- Use extra care in congested areas or when backing up. Always back up slowly, and watch carefully.
- Avoid starting or stopping abruptly.
- Vary the speed of the golf car to match the terrain of the course.
- Avoid turning the steering wheel too sharply at higher speeds.
- Always drive slowly straight up or straight down slopes – never at an angle.
- Do not make any modification or addition which affects capacity or safe operation, or make any changes not in accordance with the owner's/operator's manual.



GOLF COURSE SAFETY PROGRAM

Like all machines, golf cars can cause injury if improperly used or maintained. This section contains broad safety practices required for safe golf car operation. Before golf cars are operated, golf course personnel should establish any additional safety practices that may be required for safe operation.

Experience has shown that golf cars are safe when operated in accordance with the safety warnings affixed to every golf car. This safe operation is enhanced when golf cars are used according to the safety rules and practices established to meet the terrain and conditions of the course they are used on.

The information contained here is intended for golf course personnel responsible for golf car safety. If you are responsible for the operation and maintenance of this golf car, we encourage you to implement this golf car safety program.

DRIVER QUALIFICATIONS

Allow only authorized people to operate golf cars. It is recommended that only people who possess a valid motor vehicle driver's license be allowed to operate golf cars.

Place operation and safety instructions recommended by the golf car manufacturer, along with the golf course safety rules, in a conspicuous place near the golf car rental area or golf car pick-up area. It is also recommended that the following warning be posted in a conspicuous location:

Do Not Operate Golf Cars When Under The Influence Of Alcohol Or Drugs

GOLF COURSE SAFETY SURVEY

Perform safety surveys regularly to identify hazardous areas where golf cars should not be operated.

GOLF COURSE HAZARD PREVENTION

The following golf course hazards must be made safe:

- **Steep Grades.** Where steep grades exist, restrict golf cars to designated golf car pathways where possible. In addition, identify steep grades with a suitable warning like:

Warning: Steep Grade, Descend Slowly With Foot On Brake

- **Sharp Turns, Blind Corners, Bridge Approaches.** Chain or rope off these potentially hazardous areas or identify them with a suitable warning describing the nature of the hazard and the proper precautions to be taken to avoid the hazard.
- **Wet Areas.** Wet grass may cause a golf car to lose traction and may affect stability. Chain or rope off wet areas or identify wet areas with a suitable warning.



GOLF COURSE SAFETY PROGRAM

- **Loose Terrain.** Loose terrain may cause a golf car to lose traction and may affect stability. Repair loose terrain, chain or rope off these areas, or identify loose terrain with a suitable warning.
- **Golf Car and Pedestrian Interference.** Reroute golf car traffic or pedestrian traffic in congested areas wherever possible to prevent accidents. If it is impractical to reroute traffic, erect warning signs to warn pedestrians of golf car traffic, and to warn golf car operators to drive slowly, use caution, and watch for pedestrians.
- **Ventilation.** Properly ventilate all maintenance and storage areas in accordance with applicable fire codes and ordinances to avoid fire hazards. Ventilation is required to remove hydrogen gas from electric powered car storage areas during the charging process.

For electric powered golf cars, the amount of hydrogen gas emitted during charging depends on a number of factors, such as the condition of the batteries, the output rate of the battery charger, and the amount of time the batteries are on charge. Because of the highly volatile nature of hydrogen gas and its propensity to rise and accumulate at the ceiling in pockets, a minimum of 5 air changes per hour is recommended. Consult applicable fire and safety codes for the specific ventilation levels requirement, as well as requirements for the use of explosion proof electrical apparatus.

4

MAINTENANCE REQUIRED FOR GOLF CAR SAFETY

Practice the following to help ensure the safety of golf car occupants:

- **Preventative Maintenance.** Perform all scheduled maintenance in accordance with manufacturer's recommendations to provide the golfing patron with a safe, properly operating golf car.
- **Personnel.** Allow only qualified, trained, and authorized personnel to inspect, adjust, and maintain golf cars.
- **Parts and Materials.** Use only replacement parts and materials recommended by the manufacturer.



GOLF COURSE SAFETY PROGRAM

SAFETY PRECAUTIONS DURING MAINTENANCE

When performing maintenance, follow all safety instructions contained in the manufacturer's operation and service manuals, as well as the following safety procedures:

- Properly immobilize golf car before beginning any maintenance.
- Properly block chassis before working underneath golf car.
- Avoid fire hazards, and have appropriate fire protection equipment available.
- Before working on an electric golf car, disable the car's electrical system in accordance with the manufacturer's instructions.
- Use only properly insulated tools when working on electrically powered golf cars or around batteries.
- Maintain all safety devices including brakes, steering mechanisms, warning devices, and governors, in a safe operating condition. Do not modify these safety devices as supplied by the manufacturer.
- After each maintenance or repair, the car must be driven by a qualified, trained, and authorized person – in an area free of pedestrian traffic – to ensure proper operation and adjustment.

- Record all maintenance performed in a maintenance record log by date, name of person performing maintenance, and type of maintenance. Periodically inspect maintenance log to ensure accurate and complete entries.
- Provide operator comment cards to assist in identifying non-periodic maintenance needs for specific golf cars.
- Maintain in a legible condition all nameplates, warnings, and instructions provided by the manufacturer.
- If new nameplates, warnings, or instructions are needed, contact your Yamaha dealer.

STORAGE AND BATTERY CHARGING

Take the following precautions to ensure maintenance worker safety:

- Only use battery changing and charging facilities and procedures that are in accordance with applicable ordinances and regulations.
- Periodically inspect charging facilities and procedures to be certain that applicable safety codes, regulations, and procedures are being followed.

CONTROLS

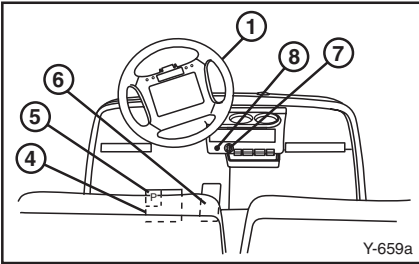

FEATURES

- ① Steering wheel
- ② Seat
- ③ Batteries
- ④ Brake pedal
- ⑤ Parking brake pedal
- ⑥ Accelerator pedal
- ⑦ Main switch
- ⑧ Drive selector switch
- ⑨ Tow switch
- ⑩ Front cowl
- ⑪ Front tire
- ⑫ Front bumper
- ⑬ Rear cowl
- ⑭ Rear bumper
- ⑮ Rear tire
- ⑯ Receptacle

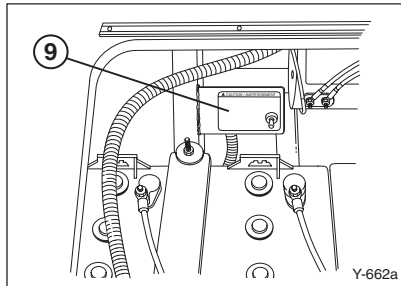
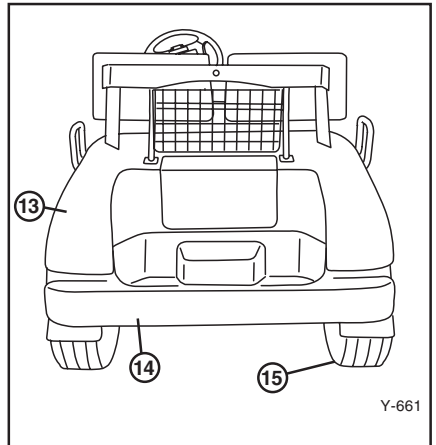
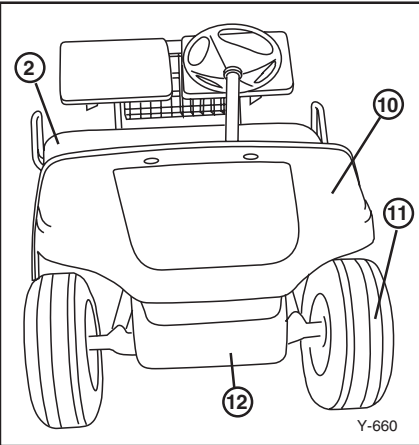
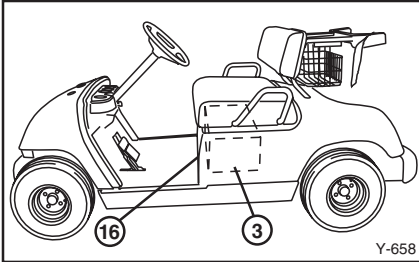

CONTROLS

MAIN SWITCH

The main switch controls the following items:

OFF

Ignition circuit is switched off.
The key can be removed only in this position.

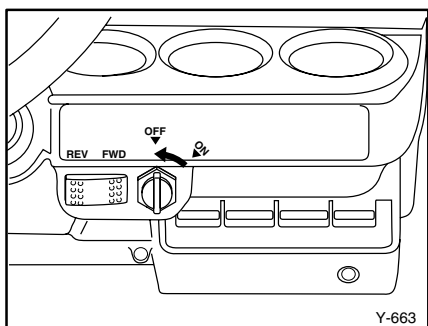

Y-663

ON

Electrical circuits are switched on.
The golf car can be driven.

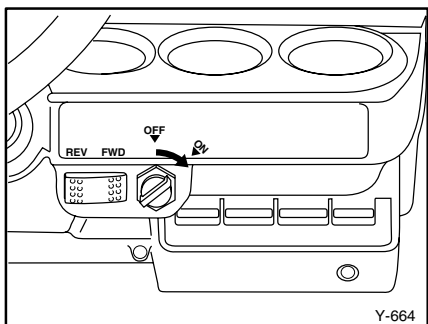

Y-664

CONTROLS

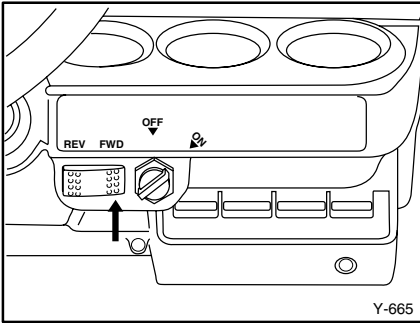

DRIVE SELECT SWITCH

The drive select switch is used to shift the golf car into forward or reverse. After coming to a complete stop, move the switch to the desired position.

Switch Position	Car Movement
FWD	FORWARD
REV	REVERSE

5

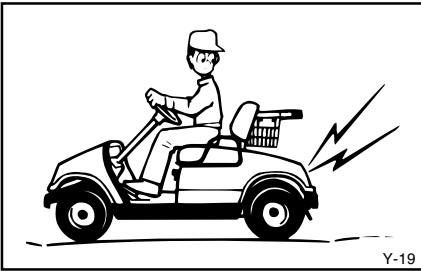

NOTE:

The back-up buzzer will beep when the drive select switch is depressed to the "REV" position.

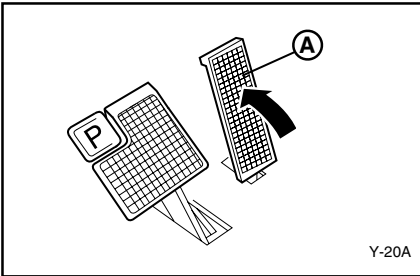

ACCELERATOR PEDAL

The accelerator pedal controls the golf car's speed.

Action	Car Speed
Depress pedal	Increase
Release pedal	Decrease

Ⓐ Accelerator pedal

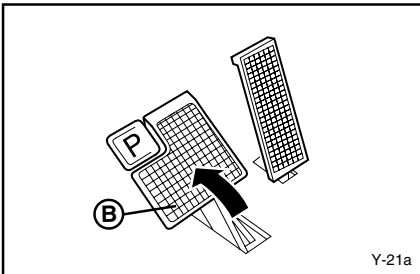

BRAKE PEDAL

Press down on the brake pedal to stop the golf car.

Ⓑ Brake pedal

CONTROLS

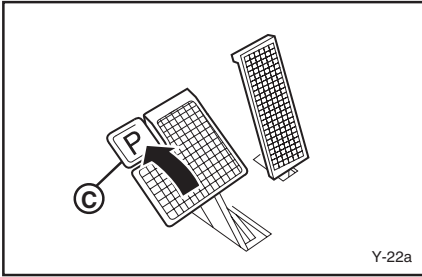

PARKING BRAKE PEDAL

Press down on the parking brake pedal whenever parking the golf car.

© Parking brake pedal

NOTE: _____
Release the parking brake by depressing the accelerator pedal.

! WARNING _____

The parking brake will automatically release when the accelerator pedal is depressed. If the main switch is in the "ON" position, depressing the accelerator may suddenly cause the golf car to move.

5

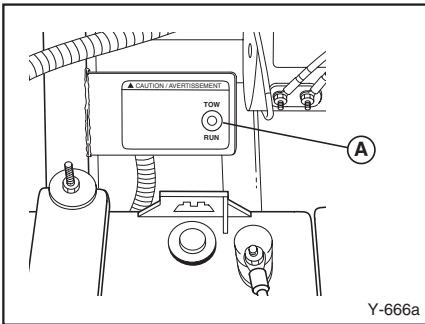

TOW SWITCH

Before operating the car, make sure the tow switch is in the "RUN" position.

Ⓐ Tow switch

NOTE: _____
Anytime the tow switch is moved from the "RUN" position to the "TOW" position and immediately moved back to "RUN", there is a delay of approximately 30 seconds before the car will run.

Make sure the tow switch is in the "TOW" position if towing this vehicle.

PRE-OPERATION CHECKS

Pre-operation checks should be made each time you use your golf car. Get in the habit of performing the following checks in the same way so that they become second nature.

⚠ WARNING

- **Be sure the main switch key is removed before performing the pre-operation checks to prevent accidental starting, and apply the parking brake to keep the car from moving.**

6

PRE-OPERATION CHECKLIST

Before each use check the following:

- ✓ Batteries
- ✓ Tire condition
- ✓ Steering system
- ✓ Back-up buzzer
- ✓ Pedal operation
- ✓ Body and chassis

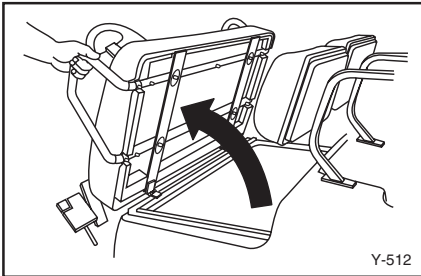

SEAT

Open the seat for checking and servicing.

PRE-OPERATION CHECKS

BATTERY

Charge batteries before each use. See charging steps in chapter 8, *Maintenance*.

Check that the batteries are held securely in place to prevent the batteries from being damaged from vibration or jarring. Also check that no battery caps are missing to prevent battery acid from spilling from the battery. Check the battery terminals for corrosion.

TIRE CONDITION

Tire Air Pressure

Check the tire air pressure before operating the golf car.

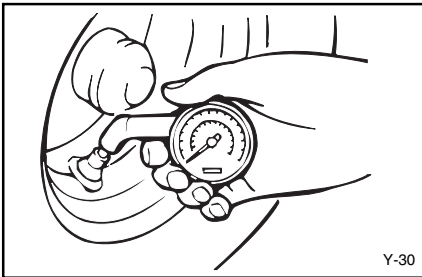

Tire pressure:

20 psi
(137 kPa, 1.4 kgf/cm²)

Tire Wear Limit

Check the tire surface for damage, cracks or embedded objects. When tire tread wears down to 0.04 in. (1 mm), replace the tire.

Ⓐ Wear limit

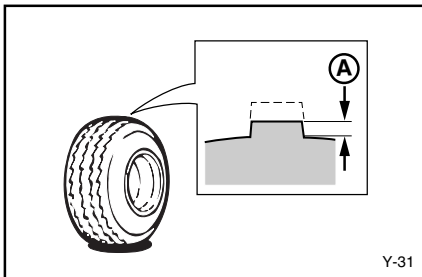

PRE-OPERATION CHECKS

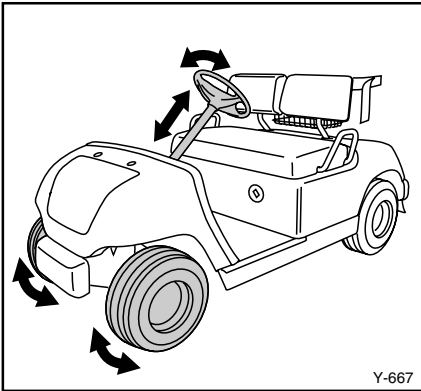

STEERING SYSTEM

Check the steering system for excessive freeplay by:

- moving the steering wheel up and down, and back and forth.
- turning the steering wheel slightly to the right and left.

If you feel excessive freeplay, or hear rattling sounds which may indicate loose steering components, consult a Yamaha dealer.

6

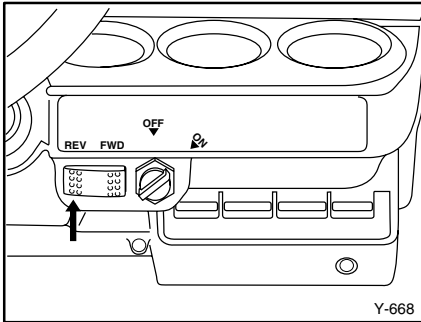

BACK-UP BUZZER

Check the back up buzzer by moving the drive select switch to “REV” for reverse. The buzzer should sound.

PEDAL OPERATION

Check the following pedal controls for proper operation. If a pedal does not work properly, consult a Yamaha dealer.

Brake Pedal

Make sure the brake pedal feels firm when pressed and returns to its original position when released.

- Ⓑ Brake pedal

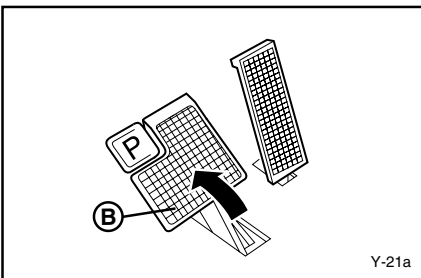

PRE-OPERATION CHECKS

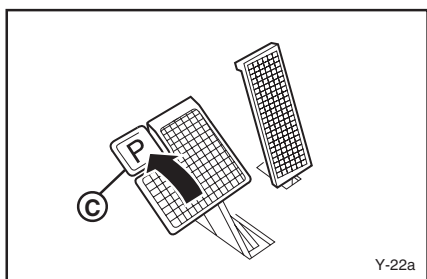

Parking Brake Pedal

Make sure the parking brake pedal locks in place with a positive click, and releases when the accelerator pedal is pressed.

Ⓒ Parking brake pedal

NOTE: _____
Release the parking brake by depressing the accelerator pedal.

Accelerator Pedal

⚠ WARNING _____

Before checking operation of the accelerator pedal, be sure the main switch is in the "OFF" position.

Make sure the accelerator pedal operates smoothly.

Ⓐ Accelerator pedal

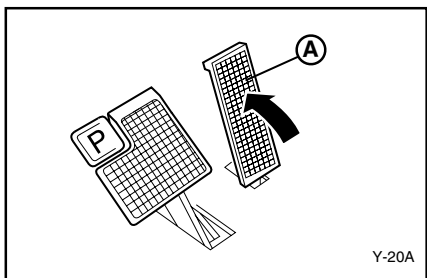

BODY AND CHASSIS

Before each use, visually inspect the golf car body and chassis for damage and/or missing parts.

OPERATION

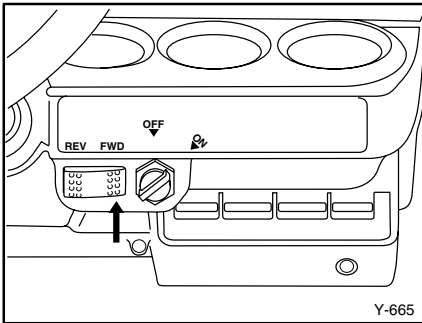

STARTING

1. With the parking brake applied, turn the drive select switch to "FWD" for forward, or "REV" for reverse.

CAUTION

Do not shift from "FWD" forward to "REV" reverse while the golf car is moving.

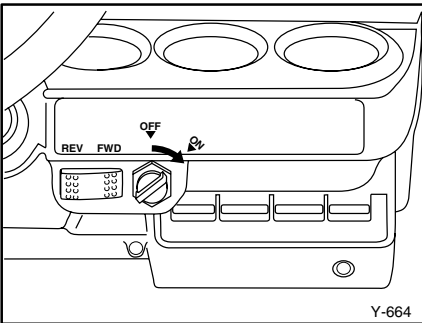

2. Turn the main switch to "ON."

⚠ WARNING

Do not depress the accelerator pedal when turning on the main switch or the golf car may suddenly start moving.

7

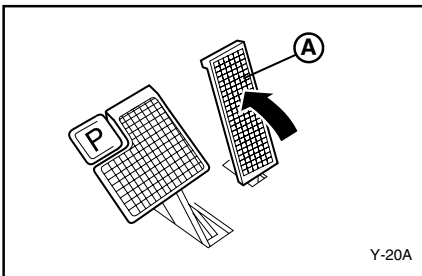

3. Check that your path is clear in the direction you plan to go, and slowly depress the accelerator pedal. The golf car will start to move.

Ⓐ Accelerator pedal

NOTE:

The parking brake automatically releases when the accelerator pedal is depressed.

OPERATION

STOPPING

To stop the golf car, gradually press down on the brake pedal.

- Ⓑ Brake pedal

When the car has come to a stop, apply the parking brake pedal and turn the main switch to "OFF."

- Ⓒ Parking brake pedal

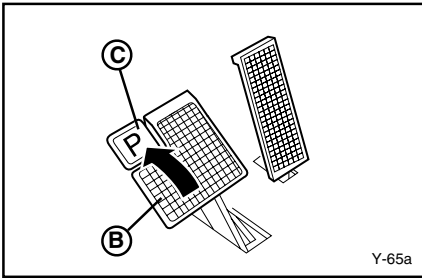

CAUTION

Do not hold the golf car on an incline with the accelerator – use the brake.

MAINTENANCE

PERIODIC MAINTENANCE CHARTS

Regular maintenance is required for the best performance and safe operation of your golf car.

WARNING

Be sure to turn off the main switch and apply the parking brake when you perform maintenance unless otherwise specified. If the owner is not familiar with machine servicing, this work should be done by a Yamaha dealer or other qualified mechanic.

MAINTENANCE

FOR G22E

C - CHECK CA - CHECK AND ADJUST R - REPLACE S - SERVICE CL - CLEAN AND LUBRICATE L - LUBRICATE

	Remarks	Pre-Operation	20 rounds 20 hours 100 miles 160 kms (Every Month)	125 rounds 125 hrs 600 mls 1000 kms (Every 6 months)	250 rounds 250 hrs 1200 mls 2000 kms (Every Year)	500 rounds 500 hrs 2500 mls 4000 kms (Every 2 years)	1000 rounds 1000 hrs 5000 mls 8000 kms (Every 4 years)	Page
PRE-OP	Charge	S	S	S	S	S	S	8-5
	Clean battery tops, check for tightness of hold-down screws and terminals	S	S	S	S	S	S	8-3/ 6-2
	Check brake pedal freeplay and adjust if necessary	C	CA	CA	CA	CA	CA	8-9/ 8-10
	Check steering operation	C	C	C	C	C	C	6-3
	Check tire pressure, tread depth, tire surface for damage	C	CA	CA	CA	CA	CA	6-2
	Check body and chassis for damage	C	C	C	C	C	C	6-4
	Check tightness of all bolts, nuts, and screws	C	C	C	C	C	C	*
	Check reverse buzzer operation	C	C	C	C	C	C	6-3
EVERY MONTH	Check electrolyte level		C	C	C	C	C	8-3/8-4
	Check for loose or broken connections		C	C	C	C	C	*
	Clean/Lube pedal control area		CL					—
EVERY 6 MONTHS	Check all wire insulation for cracks and/or worn spots			C	C	C	C	*
	Check shock absorbers for oil leaks and damaged springs			C	C	C	C	*
EVERY YEAR	Perform a discharge test				S	S	S	*
	Apply Terminal protectant				S	S	S	—
	Check shoe lining thickness and rear axle bearing play				C	C	C	*
	Check steering knuckle bushing freeplay / Adjust wheel alignment				CA	CA	CA	*
	Check wheel nut tightness, front wheel bearing play				C	C	C	8-9/*
	Check gear box oil level and leakage				C	C	C	8-8
	Check operation and adjust pedal stop if necessary				CA	CA	CA	*
EVERY 4 YEARS	Replace gear box oil						R	*
	Check for grease leakage; adjust gear box if necessary						CA	8-8

* Items without a page number reference should be serviced by a Yamaha dealer or other qualified mechanic. This manual does not contain these procedures. They are contained in the Service Manual.

Battery Care

⚠ WARNING

Battery electrolyte is poisonous and dangerous, causing severe burns, etc. It contains sulfuric acid. Avoid contact with skin, eyes, or clothing.

Antidote:

EXTERNAL: Flush with water.

INTERNAL: Drink large quantities of water or milk. Follow with milk of magnesia, beaten egg, or vegetable oil. Call physician immediately.

EYES: Flush with water for 15 minutes and get prompt medical attention.

Batteries produce explosive gases. Keep sparks, flame, cigarettes, etc., away.

Ventilate when charging or using in enclosed space. Always shield eyes when working near batteries.

KEEP OUT OF REACH OF CHILDREN.

Six 8-volt deep cycle batteries provide power for your electric golf car and must be properly maintained and recharged for maximum performance and service life.

To maintain your batteries:

1. Clean the tops of the batteries with a solution of baking soda and water, as necessary, to remove corrosion.

CAUTION

Do not allow cleaning solution to enter battery cells.

2. Check the fluid level before and after charging.

MAINTENANCE

- **Before charging:** only add distilled water if fluid is below the top of the plates, and then add just enough to cover plates.
- **After charging:** check that the fluid level is approximately 1/4 to 1/2 inch above the plates and 1/4 to 3/8 inch below the level indicator. If the fluid level is low, carefully add distilled water. Adding distilled water **after** charging helps prevent boil over.

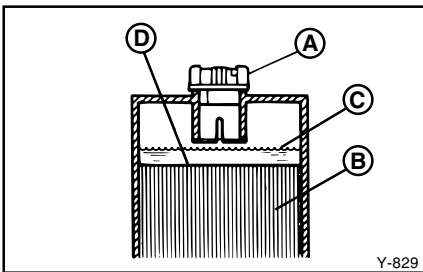

- (A) Battery cap
- (B) Plates
- (C) Maximum fluid level
- (D) Minimum fluid level

CAUTION

Normal tap water contains minerals which are harmful to a battery; therefore, refill only with distilled water.

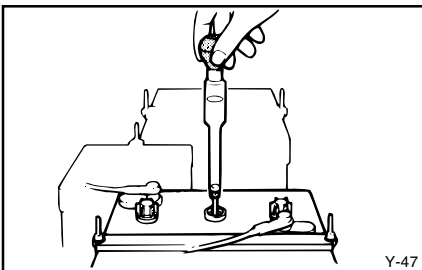

- Using a hydrometer, check the specific gravity of the battery fluid in each cell against the readings on the chart below. Consult a Yamaha dealer if any low readings are found, or if readings vary more than one point between cells.

Temperature		Satisfactory Uncorrected Hydrometer Reading
°F	°C	
120	48.9	1.244
110	43.3	1.248
100	37.8	1.252
90	32.2	1.256
80	26.7	1.260
70	21.1	1.264
60	15.6	1.268
50	10.0	1.272
40	4.4	1.276
30	-1.1	1.280

MAINTENANCE

Battery Charging

⚠ WARNING

Read and understand the owner's manual provided with your golf car's battery charger before charging batteries.

⚠ WARNING

Explosive hydrogen gas is produced while batteries are being charged. Only charge batteries in well ventilated areas (a minimum of 5 air changes per hour is recommended).

To charge the batteries in your golf car, follow the instructions contained in your battery charger's owner's manual.

The following is a summary of the charging steps. **Do not attempt to recharge your golf car's batteries without thoroughly reading and understanding the owner's manual provided with your charger.**

1. Turn main switch key to "OFF" position.
2. With the charger properly connected and grounded (see charger's owner's manual), insert the DC output plug into the golf car receptacle.

CAUTION

Use only battery chargers that are rated for use with 48 volt Yamaha Golf Cars. Thoroughly read and understand the user manual supplied with your 48 volt charger.

8

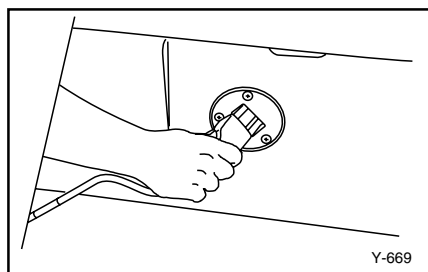
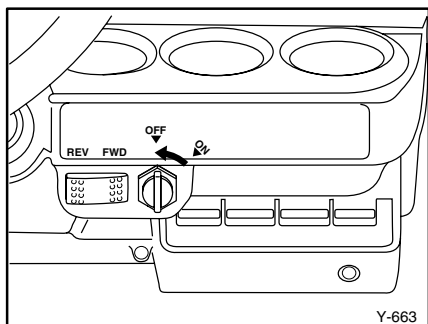

MAINTENANCE

⚠ WARNING

Do not disconnect the DC output cord from the battery receptacle when the charger is on or an arc could occur that may cause an explosion.

3. The charger will turn off automatically when the batteries reach full charge.
4. After the charger has turned off, disconnect the DC output plug from the golf car receptacle by grasping the plug body and pulling the plug straight out of the receptacle.

Battery Installation

⚠ WARNING

When working with batteries, do not put wrenches or other metal objects across the battery terminals. An arc can occur causing explosion of the battery.

1. Install the battery holddown plates as shown.

- (A) Forward
- (B) Battery
- (C) Battery fitting plate

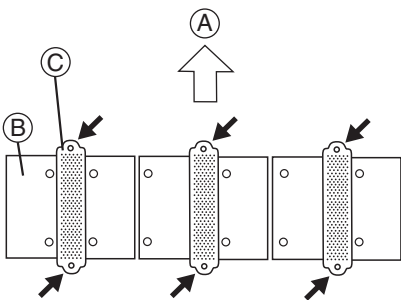

Y-751a

MAINTENANCE

FORWARD

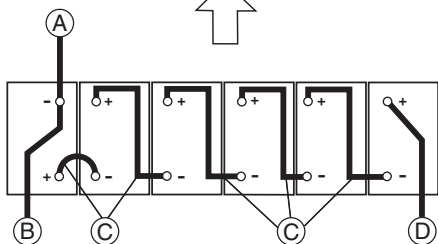

Y-672a

2. Connect the wire leads as shown.

- Ⓐ Forward
- Ⓑ To receptacle
- Ⓒ To motor control unit
- Ⓓ Between batteries
To relay
- Ⓔ

⚠ WARNING

When installing batteries:

- Carefully place battery cables and holddowns making sure that cables do not lay across vent caps.
- Always remove the negative (-) cable to the motor controller first, and install it last.

CAUTION

Do not overtighten the battery holddown nuts. Excessive force will damage the battery casing.

8

Fuse Replacement

⚠ WARNING

Be sure to use the specified fuse. Using a wrong fuse can cause electrical system damage and create a fire hazard.

CAUTION

When replacing a fuse be sure the main switch is turned off to prevent accidental short-circuiting.

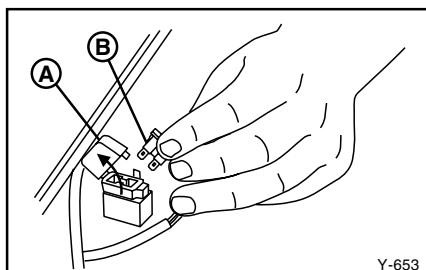

Y-653

Fuse Type:
3 Amp, Blade Style

- Ⓐ Fuse case
- Ⓑ Fuse

MAINTENANCE

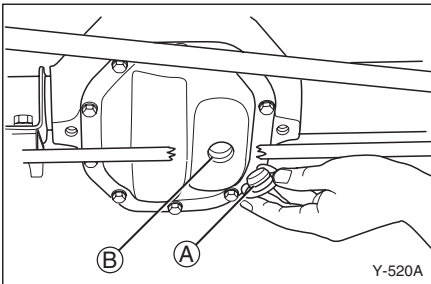
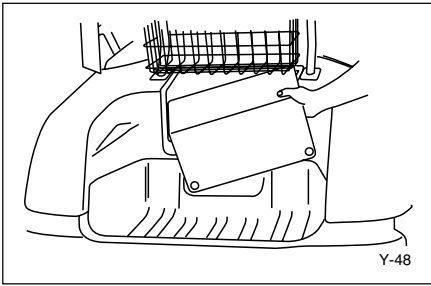

Gear Box Oil

To check gear box oil level:

1. Place the golf car on a level surface.
2. Remove the access panel by removing the rivets in the two lower corners of the panel and pulling the panel from the car.
3. Remove the oil level plug (A).
4. Add gear oil little by little until oil flows from the level plug hole (B).

Recommended oil:
SAE 90 gear oil

Gearcase capacity:
0.32 US qt
(300 mL, 300 cc)

5. Allow excess gear oil to flow out until it stops.

CAUTION

Do not allow foreign material to enter the gear box.

6. Reinstall the oil level plug.

NOTE: _____
For gear oil replacement, consult a Yamaha dealer or other qualified mechanic.

MAINTENANCE

CAUTION

Before performing wheel or brake maintenance, verify that the main switch is in the “OFF” position.

Wheel Replacement

To remove and install a wheel on your golf car:

1. With the wheels blocked to prevent the golf car from moving, loosen the wheel nuts.
2. Elevate the golf car with a jack and remove the wheel nuts and the wheel.
3. Reverse the removal steps when installing the wheel.

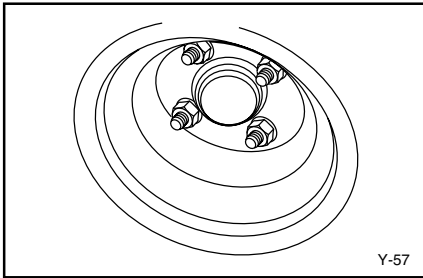

Wheel nut tightening torque:
58 ft·lb (80 Nm, 8.0 m·kg)

8

Brake Adjustment

The brakes on your golf car are self-adjusting.

Before you operate the car, press down on the brake pedal several times to make sure the brakes are functioning properly.

⚠ WARNING

Consult your Yamaha dealer before using your golf car if you suspect brake problems. Brake failure could result in a serious accident.

MAINTENANCE

Brake Pedal Free Play Adjustment

CAUTION

Before adjusting brake pedal free play, pump the brake pedal several times to self-adjust the brakes.

To adjust the brake pedal free play:

1. Remove the service lid from the floor of the golf car.
2. Check the brake pedal free play by pressing against the pedal with two fingers (using light force) and measuring the distance the pedal travels before resistance is felt.

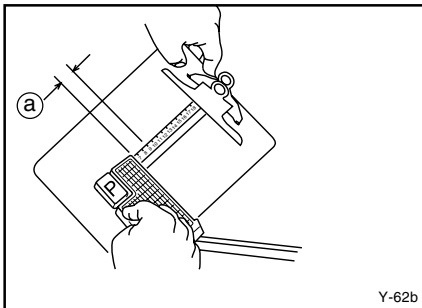
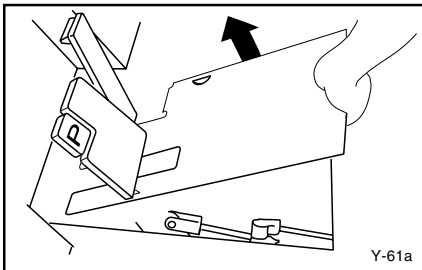

Brake pedal free play (a):
20-25 mm (0.79-0.98 in.)

3. If the free play distance needs adjusting, loosen the lock nut and turn the adjusting nut in or out until the free play specification is met. Then tighten the lock nut in place.

⚠ WARNING

Do not overtighten the brake cables. The self adjusters may not operate properly, reducing braking performance.

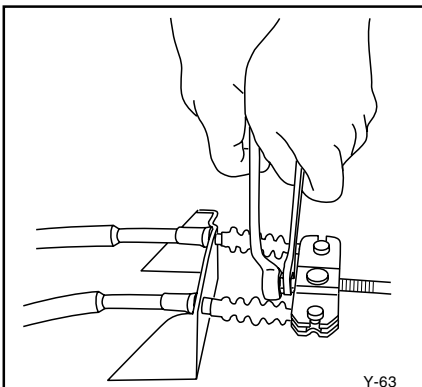

STORAGE

Perform the following preparations when storing your golf car for extended periods of time:

NOTE: _____

Turn main switch key to “OFF” position, remove key, and store key in a safe place. Move the tow switch into the “TOW” position.

CHASSIS PREPARATION

1. Verify the tire pressure is set to 20 psi (137 kPa, 1.4 kgf/cm²).
2. Clean exterior of the golf car and apply a rust inhibitor.
3. Cover the golf car with a breathable cover and store it in a dry, well-ventilated area.

BATTERY PREPARATION

1. Recharge the batteries and check the fluid levels at least once a month.

CAUTION _____

Do not allow cleaning solution to enter battery cells.

2. Clean the tops of the batteries with a solution of baking soda and water, as necessary, to remove corrosion.

SPECIFICATIONS

GENERAL SPECIFICATIONS

Items	G22E
Dimensions:	
Overall length	93.9 in. (2385 mm)
Overall width	47.2 in. (1200 mm)
Overall height (steering height)	46.9 in. (1190 mm)
Height of floor	11.8 in. (300 mm)
Wheelbase	64.3 in. (1632 mm)
Tread:	
Front	34.3 in. (870 mm)
Rear	38.6 in. (980 mm)
Min. ground clearance	3.8 in. (97 mm)
Weight:	
Dry weight (without battery)	549 lb (249 kg)
Performance:	
Factory speed setting	12 mph (19 km/h)
Maximum speed	15 mph (24 km/h)
Minimum turning radius	114.2 in. (2.9 m)
Seating capacity	2 persons
Hill climbing ability	20° on pavement

TRANSMISSION

Items	G22E
Differential/reduction gear:	
Differential type	Bevel gear
Lubricant/capacity	SAE 90 gear oil/ 0.32 US qt (300 mL, 300 cc)

BATTERIES

Items	G22E
Battery:	BCI group GC-2H RC: minimum 105 min

SPECIFICATIONS

CHASSIS

Items	G22E
Steering system: Type Steering angle (L.H.) Steering angle (R.H.)	Rack and Pinion 1.55 turn 1.55 turn
Brakes: Brake system Type of brake Brake pedal freeplay linkage adjustment (Brake cable end play)	Mechanical drum brake on each rear wheel with self-adjusters. Dual internal expanding shoe. Leading/trailing shoes (self-adjusting) 20-25 mm 0.004-0.02 in. (0.1-0.5 mm)
Parking brake: Type	Foot type; parking brake with automatic release.
Release timing (With pedal segment in second notch) (Bolt heads round parallel to arm)	0.000 ~ 0.001 in. (0.0 ~ 0.3 mm)
Wheel: Tire size: Front Rear Rim size: Tire pressure:	18 x 8.50-8.00/4 PR 18 x 8.50-8.00/4 PR 7.00-1-8.00 20 psi (137 kPa, 1.4 kgf/cm ²)

G22E WIRING DIAGRAM

WIRING

- ① Main switch
- ② Tow/storage switch
- ③ Accelerator stop switch
- ④ Buzzer
- ⑤ Directional switch
- ⑥ DC motor
- ⑦ Controller
- ⑧ Throttle sensor
- ⑨ Relay
- ⑩ Receptacle
- ⑪ Fuse (3A)
- ⑫ Batteries (6 x 8V)

COLOR CODE

B.....	Black
L.....	Blue
G.....	Green
Y.....	Yellow
R.....	Red
P.....	Pink
Br.....	Brown
W.....	White
B/R.....	Black/Red
Y/B.....	Yellow/Black
R/Y.....	Red/Yellow
R/W.....	Red/White
B/W.....	Black/White

Y-671

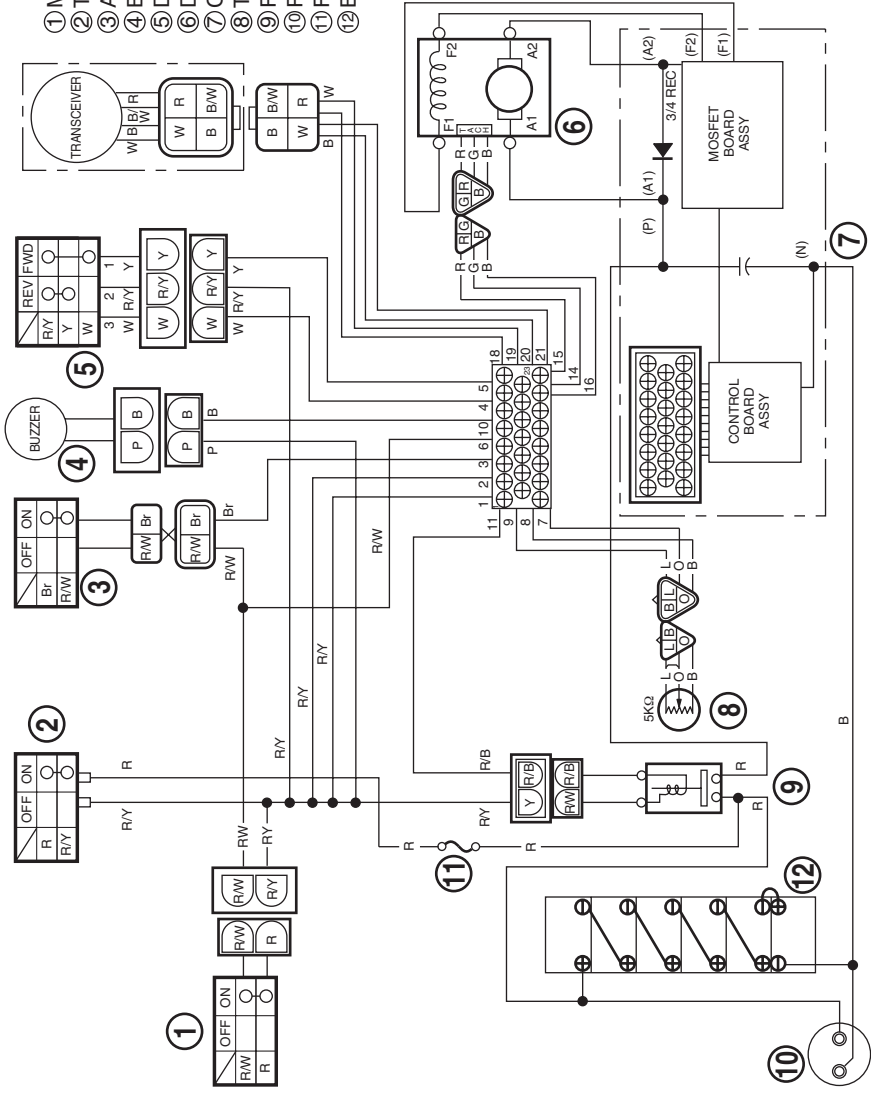

NOTES

